

TYPE 1

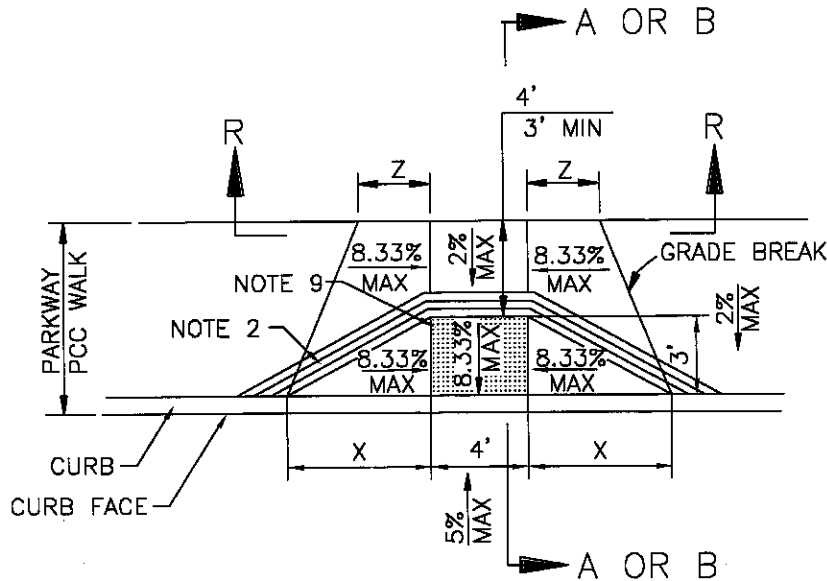

SEE FIGURE 1

TYPE 2

CASE A

REVISIONS		CITY OF LONG BEACH, CALIFORNIA DEPARTMENT OF PUBLIC WORKS	STANDARD PLAN NO.
NO.	DATE		
1	8/11/05	CURB RAMP	122
2			
3			
4			
APPROVED BY: <i>Mark Christoffel</i>		DATE: <u>8/24/05</u>	SHEET
CITY ENGINEER R.E. No. <u>40599</u>		EX. DATE <u>03/31/07</u>	<u>1</u> OF <u>9</u>

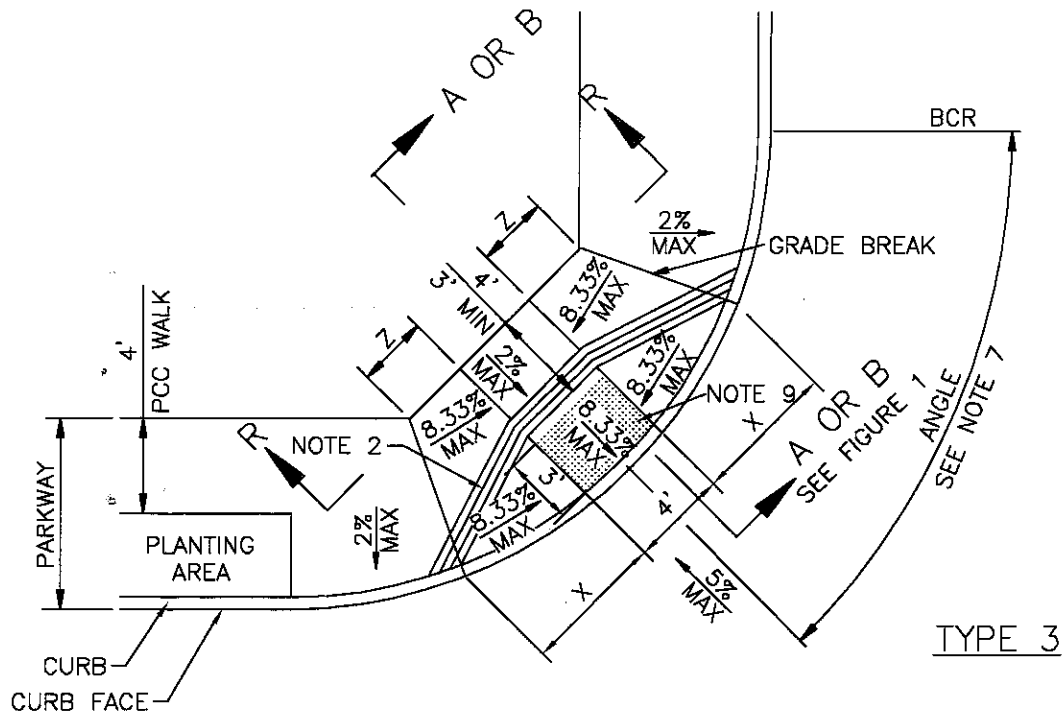

TYPE 3

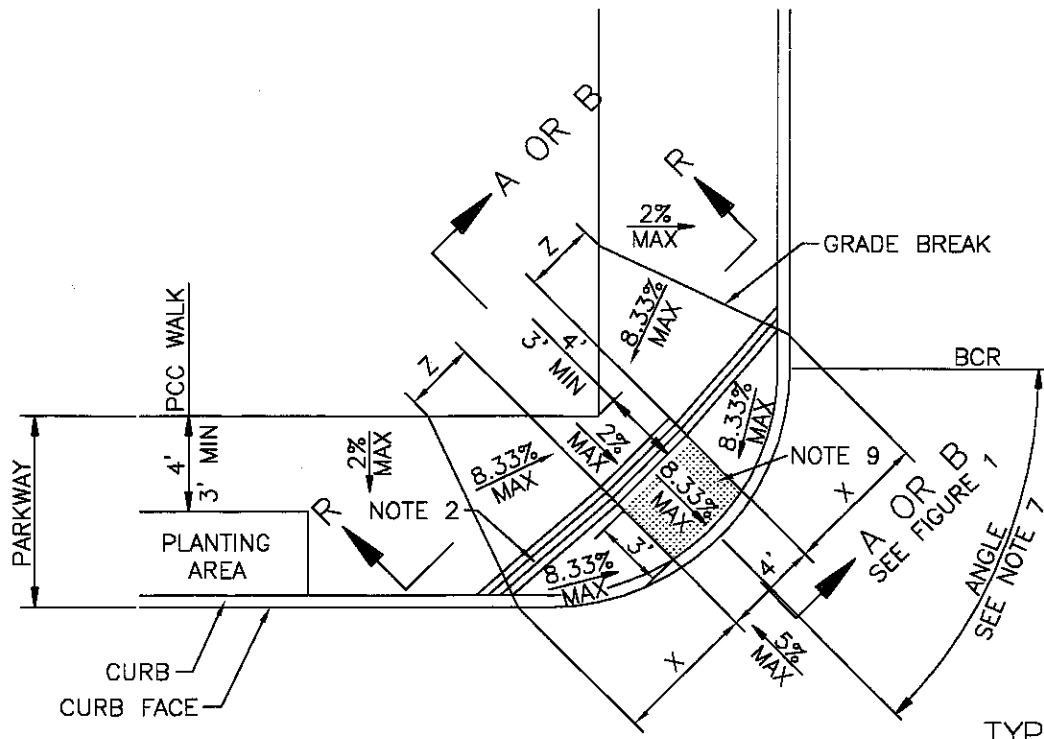

TYPE 4

CASE A

REVISIONS		CITY OF LONG BEACH, CALIFORNIA DEPARTMENT OF PUBLIC WORKS	STANDARD PLAN NO.
NO.	DATE		
1	8/11/05	CURB RAMP	122
2			
3			
4			
APPROVED BY: <i>Mad. [Signature]</i>		DATE: 8/24/05	SHEET
CITY ENGINEER R.E. No. 40599		EX. DATE 03/31/07	2 OF 9

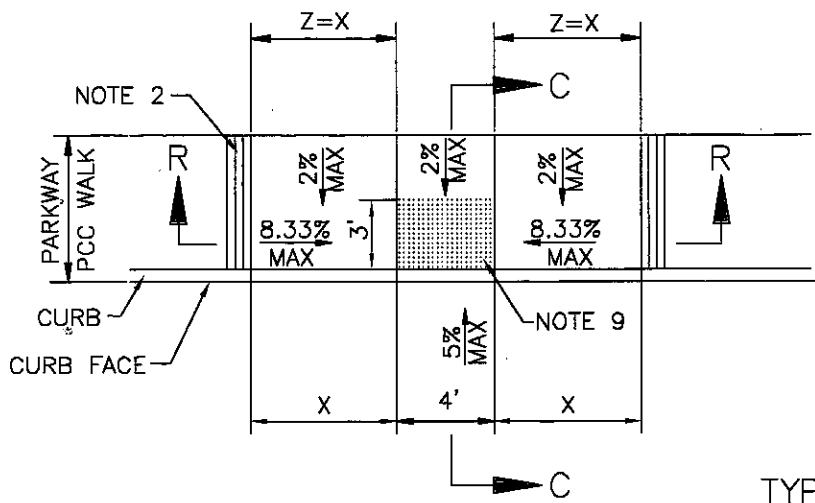

TYPE 1

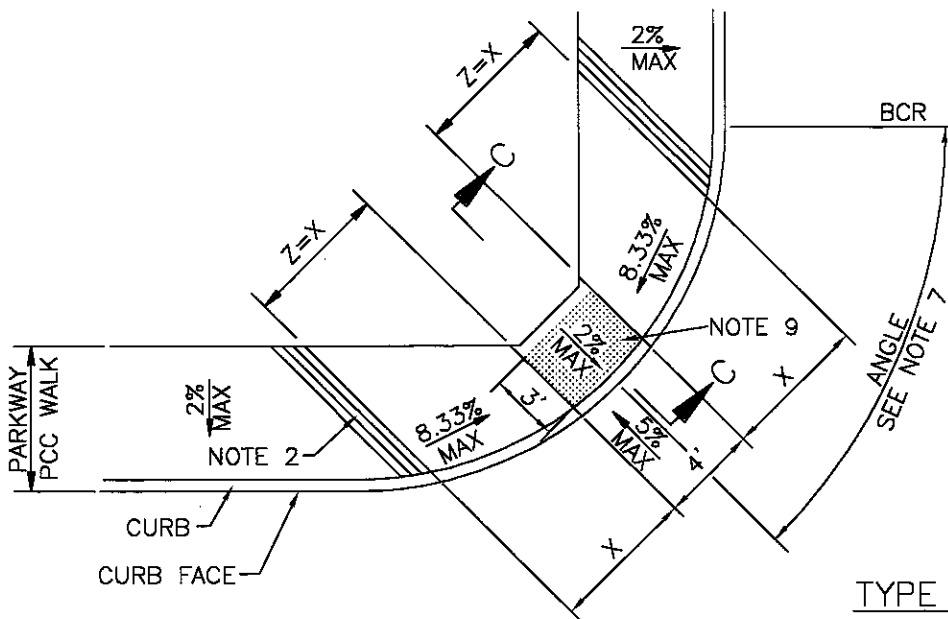

TYPE 2

CASE B

REVISIONS		CITY OF LONG BEACH, CALIFORNIA DEPARTMENT OF PUBLIC WORKS	STANDARD PLAN NO.
NO.	DATE		
1	8/11/05	CURB RAMP	122
2			
3			
4			
APPROVED BY: <i>Mal Cliff</i>		DATE: 8/24/05	SHEET
CITY ENGINEER R.E. No. 40599		EX. DATE 03/31/07	3 OF 9

SKEW ANGLE $\alpha=45^\circ$
 OFFSET $b=0$
 UNLESS OTHERWISE
 NOTED ON PLANS

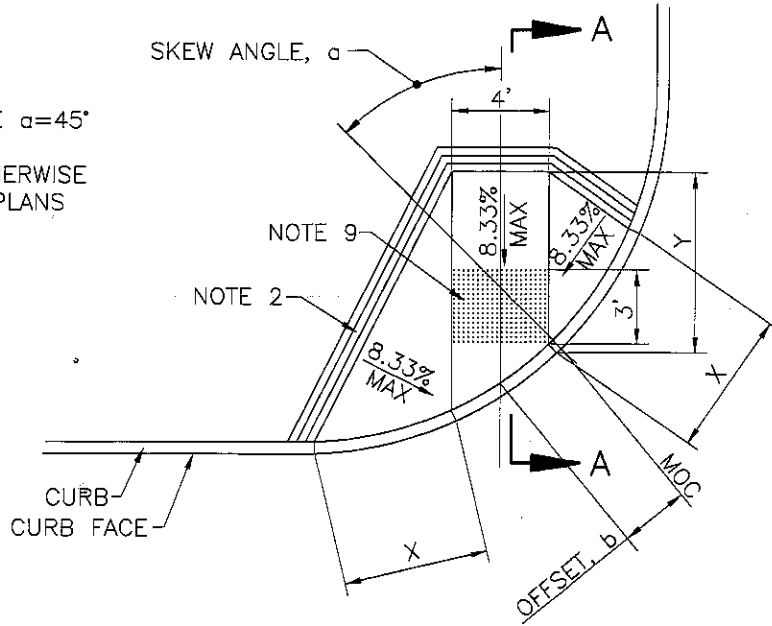

CASE C

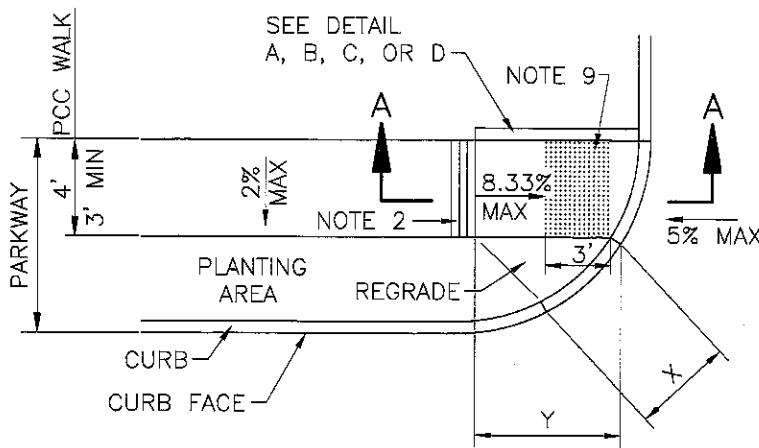

TYPE 1

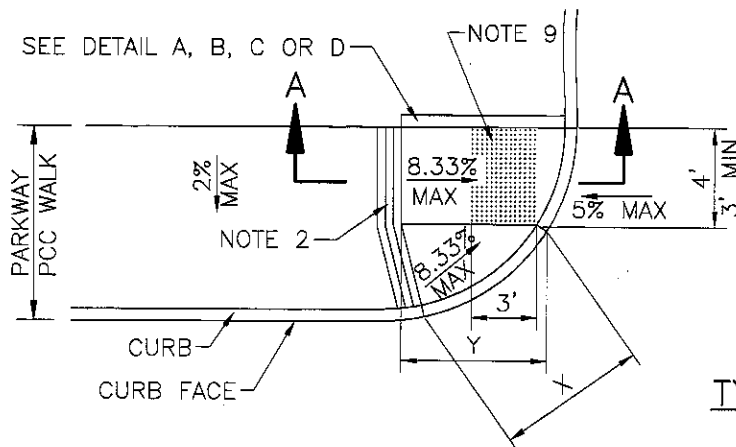

TYPE 2

CASE D

REVISIONS		CITY OF LONG BEACH, CALIFORNIA DEPARTMENT OF PUBLIC WORKS	STANDARD PLAN NO.
NO.	DATE		
1	8/11/05	CURB RAMP	122
2	9/26/09		
3			
4			
APPROVED BY: <i>[Signature]</i>		DATE: <i>9/2/09</i>	SHEET
CITY ENGINEER R.E. No. 40599		EX. DATE: <i>05/31/11</i>	4 OF 9

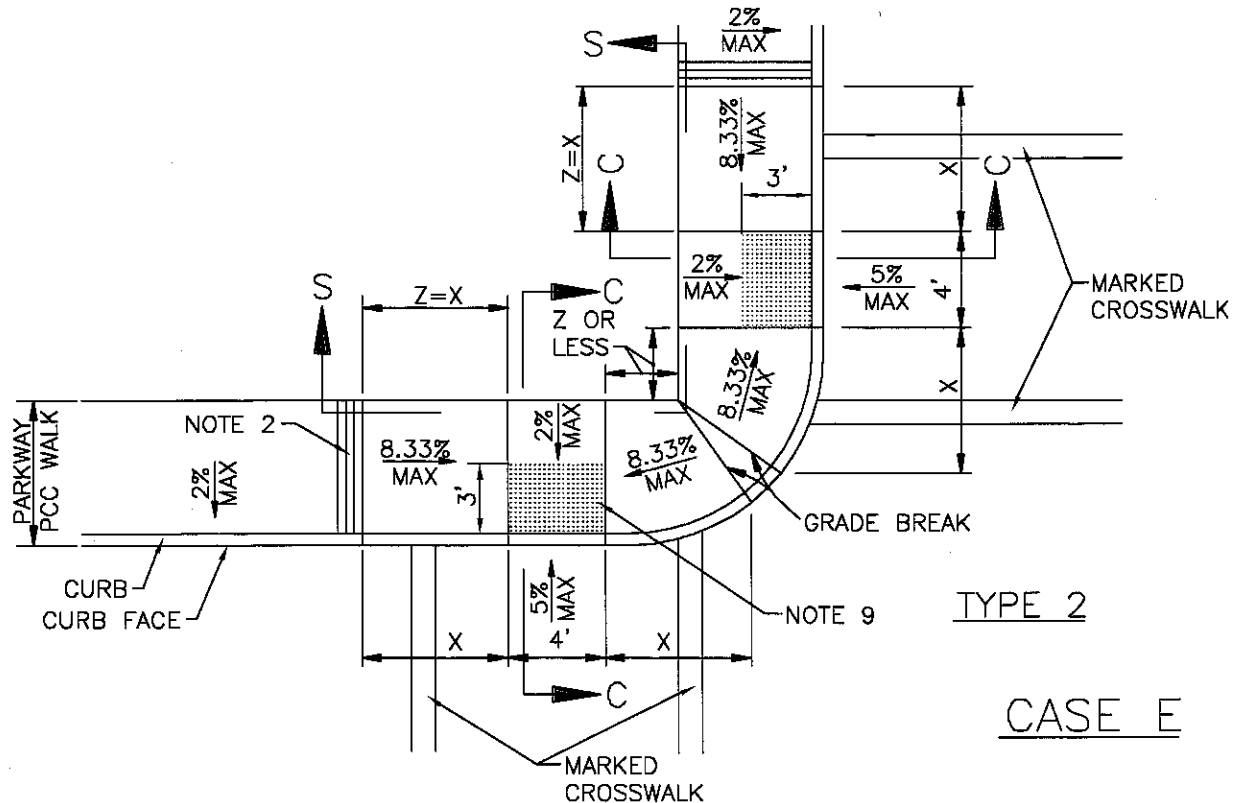
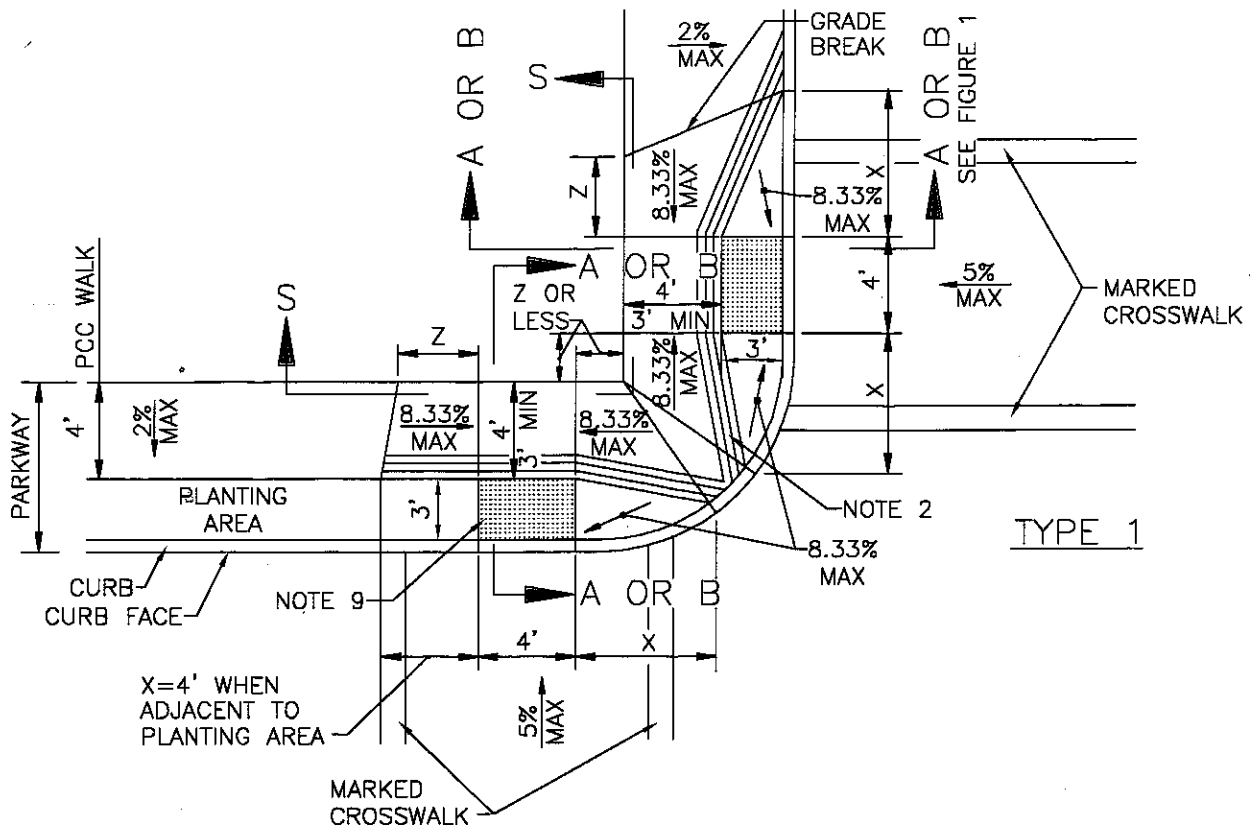

CASE E

REVISIONS		CITY OF LONG BEACH, CALIFORNIA DEPARTMENT OF PUBLIC WORKS	STANDARD PLAN NO.
NO.	DATE		
1	8/11/05	CURB RAMP	122
2			
3			
4			
APPROVED BY: <i>Mal Chiff</i>		DATE: 8/24/05	SHEET
CITY ENGINEER R.E. No. 40599		EX. DATE 03/31/07	5 OF 9

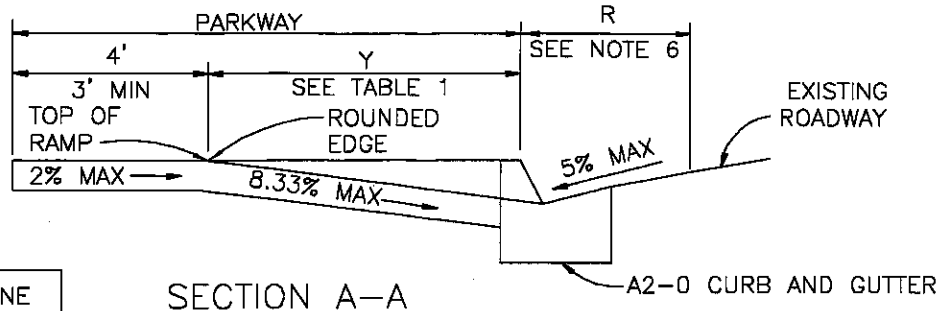

USE FIGURE 1 TO DETERMINE WHICH OF SECTIONS A-A, B-B OR C-C IS APPROPRIATE.

DEPRESS BACK OF WALK SEE DETAIL A, B, C OR D, SHEET 9.

SECTION A-A

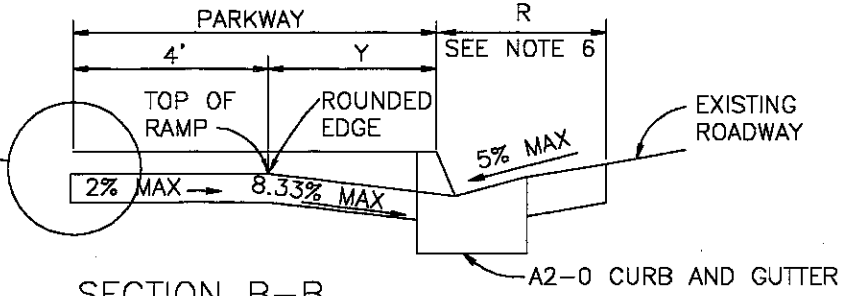

SECTION B-B

DEPRESS BACK OF WALK SEE DETAIL A, B, C OR D, SHEET 9.

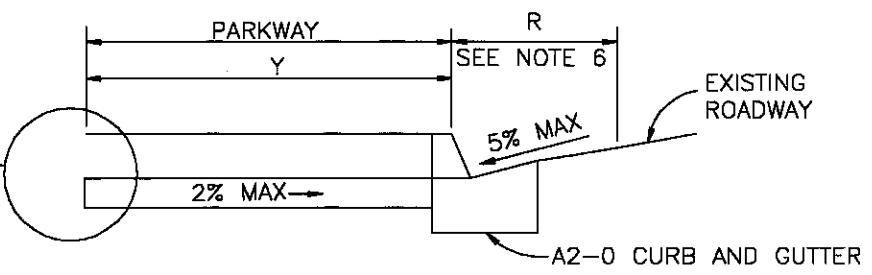

SECTION C-C

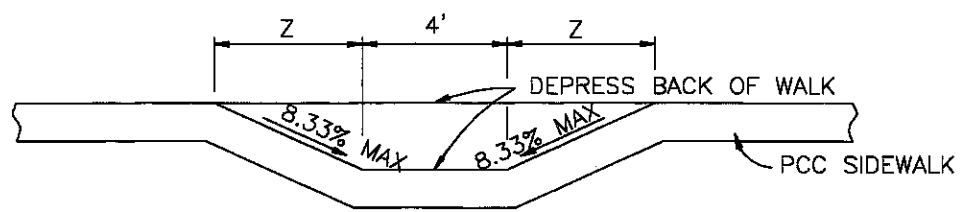

SECTION R-R

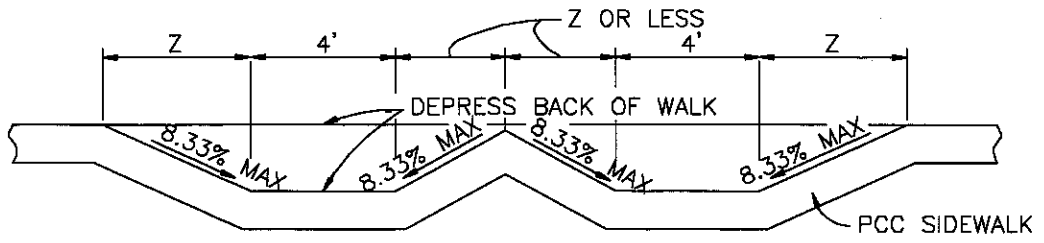

SECTION S-S

REVISIONS	
NO.	DATE
1	8/11/05
2	
3	
4	

CITY OF LONG BEACH, CALIFORNIA
DEPARTMENT OF PUBLIC WORKS

STANDARD PLAN NO.

CURB RAMP

122

APPROVED BY: *Mal O'Neil*
CITY ENGINEER R.E. No. 40599

DATE: 8/24/05
EX. DATE 03/31/07

SHEET

6 OF 9

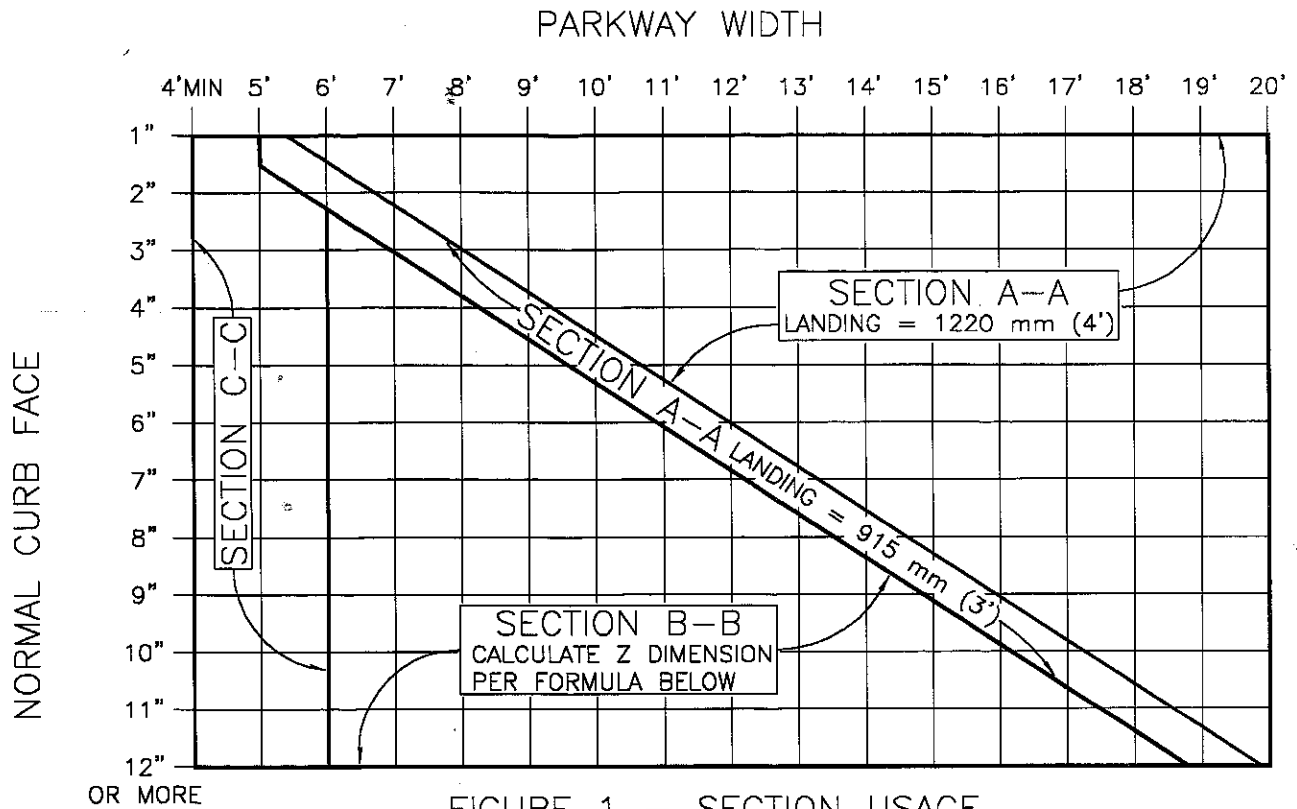

FIGURE 1 - SECTION USAGE

NORMAL CURB FACE, mm (INCHES)	X, mm (FT)	Section A-A Y ₂ , mm (FT)
50 (2")	1220 (4.00') MIN	790 (2.63')
75 (3")	1220 (4.00') MIN	1185 (3.95')
100 (4")	1220 (4.00')	1580 (5.26')
125 (5")	1525 (5.00')	1975 (6.58')
150 (6")	1830 (6.00')	2370 (7.90')
175 (7")	2135 (7.00')	2765 (9.21')
200 (8")	2440 (8.00')	3160 (10.53')
225 (9")	2745 (9.00')	3555 (11.84')
250 (10")	3050 (10.00')	3945 (13.16')
275 (11")	3355 (11.00')	4340 (14.74')
300 (12")	3660 (12.00')	4735 (15.79')

WHERE FIGURE 1 SHOWS USE OF SECTION B-B, FIGURE Z DIMENSION AS FOLLOWS:

W=PARKWAY WIDTH

L=LANDING WIDTH, 1220 mm (4') TYP, 915 mm (3') MIN

$$Z=[(Y+L)-W] \times 0.760$$

IF (Y+L) < W, THEN Z=0

TABLE 1 SHOWS X FOR A FLARE SLOPE OF 8.33% AT THE CURB FACE. IF L IS 1220 mm (4') OR MORE, X MAY BE MULTIPLIED BY 0.833 FOR A MAXIMUM FLARE SLOPE OF 10% AT THE CURB FACE.

TABLE 1 - X AND Y VALUES

REVISIONS		CITY OF LONG BEACH, CALIFORNIA DEPARTMENT OF PUBLIC WORKS	STANDARD PLAN NO.
NO.	DATE		
1	8/11/05	CURB RAMP	122
2			
3			
APPROVED BY: <i>Mal Outfit</i>		DATE: 8/24/05	SHEET
CITY ENGINEER R.E. No. 40599		EX. DATE 03/31/07	7 OF 9

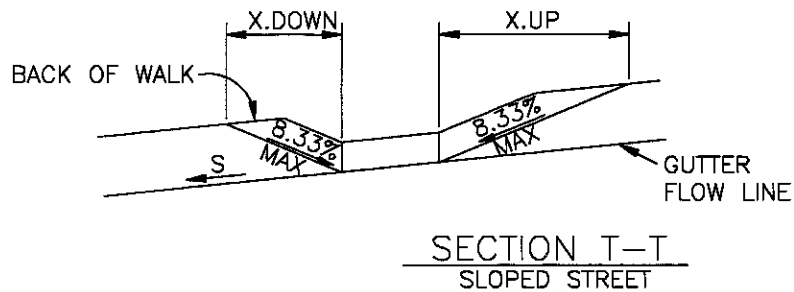
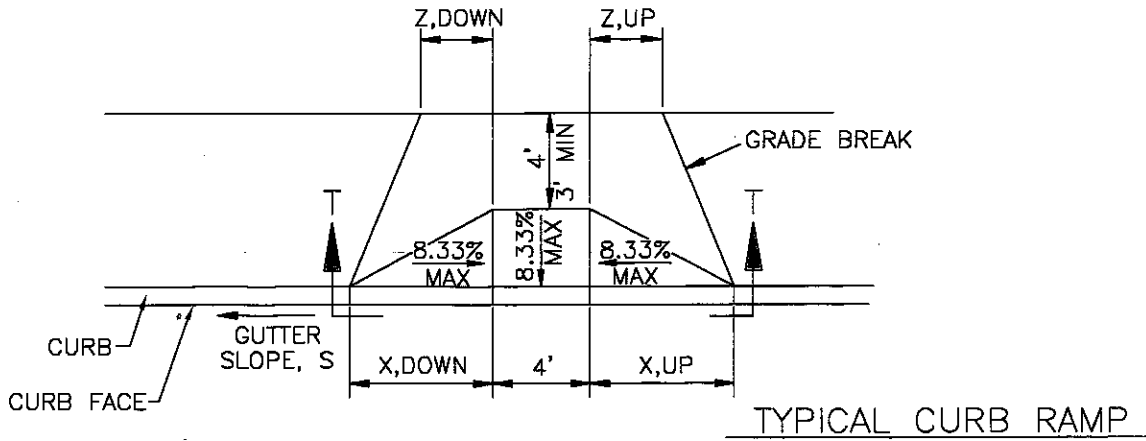

FOR SLOPED STREETS, MULTIPLY THE DIMENSIONS PARALLEL TO THE STREET, X AND Z, UPSTREAM AND DOWNSTREAM OF THE RAMP, BY THE FACTORS IN THE FOLLOWING TABLE.

FOR EXAMPLE, $X,DOWN = X \times K,DOWN$

S	K,DOWN	K,UP
0%	1.000	1.000
0.2%	0.977	1.025
0.5%	0.943	1.064
1%	0.893	1.136
2%	0.806	1.316
3%	0.735	1.563
4%	0.676	1.923
5%	0.625	2.500

TABLE 2 - SLOPE ADJUSTMENTS

SLOPED STREET ADJUSTMENTS

REVISIONS		CITY OF LONG BEACH, CALIFORNIA DEPARTMENT OF PUBLIC WORKS	STANDARD PLAN NO.
NO.	DATE		
1	8/11/05	CURB RAMP	122
2			
3			
4			
APPROVED BY: <i>[Signature]</i>		DATE: <i>8/24/05</i>	SHEET
CITY ENGINEER R.Z. No. 40599		EX. DATE <i>03/31/07</i>	8 OF 9

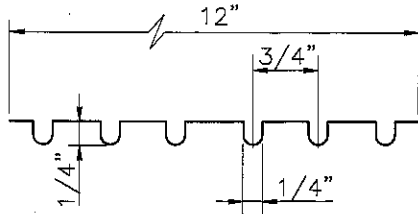

GROOVING DETAIL

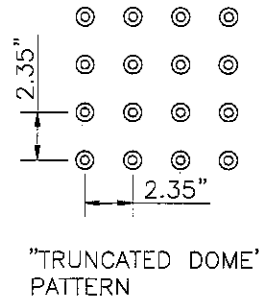

DETECTABLE WARNING SURFACE DETAIL

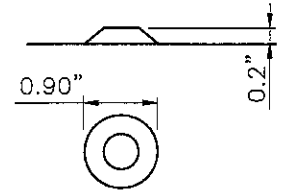

SINGLE "TRUNCATED DOME"

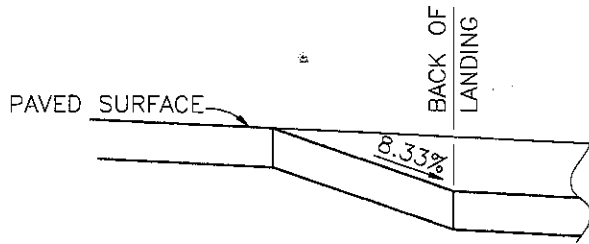

DETAIL A

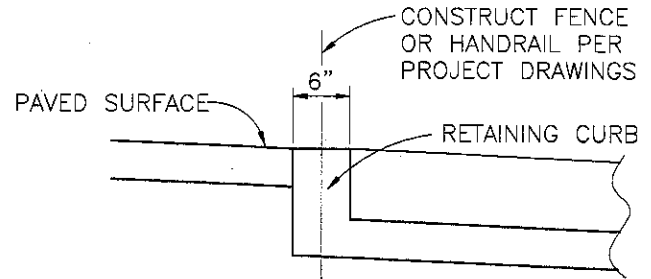

DETAIL B

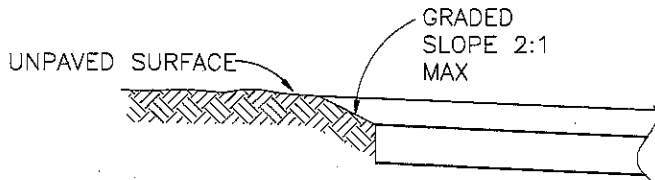

DETAIL C

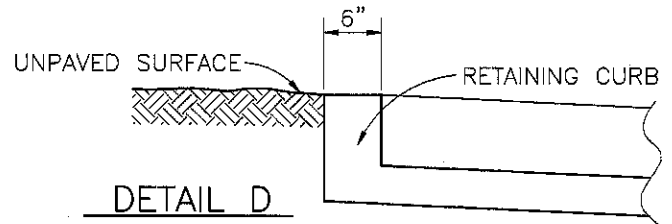

DETAIL D

GENERAL NOTES:

1. CONCRETE SHALL BE CLASS 520-C-2500 AND SHALL BE 3" THICK
2. THE RAMP SURFACE SHALL HAVE A 12" WIDE BORDER WITH 1/4" GROOVES APPROXIMATELY 3/4" O.C., SEE GROOVING DETAIL.
3. THE RAMP SURFACE SHALL HAVE A TRANSVERSE BROOMED SURFACE TEXTURE.
4. USE DETAIL "A" OR "B" IF EXISTING SURFACE BEHIND RIGHT OF WAY IS PAVED.
5. USE DETAIL "C" OR "D" IF EXISTING SURFACE BEHIND RIGHT OF WAY IS UNPAVED.
6. MAINTAIN MAX 5% APPROACH SLOPE ACCROSS DIMENSION R, R = 4' UNLESS OTHERWISE SHOWN ON PLAN.
7. ANGLE = $\Delta/2$ UNLESS OTHERWISE SHOWN ON PLAN, Δ =CURB RETURN CENTRAL ANGLE.
8. SLOPE AT THE FLARED SIDES (SIDE SLOPES) SHALL NOT EXCEED 10% AT THE CURB.
9. CONSTRUCT DETECTABLE WARNING SURFACE PER DETAIL THIS SHEET. MATERIAL SHALL BE PER CONTRACT DOCUMENTS OR PERMIT REQUIREMENTS.

REVISIONS		CITY OF LONG BEACH, CALIFORNIA DEPARTMENT OF PUBLIC WORKS	STANDARD PLAN NO.
NO.	DATE		
1	8/11/05	CURB RAMP	122
2	9/26/09		
3		APPROVED BY: <i>Malcolm</i> CITY ENGINEER R.E. No. 40599	SHEET 9 OF 9
4			
		DATE: 9/2/09	EX. DATE: 03/31/11