

AT STREET LIGHT

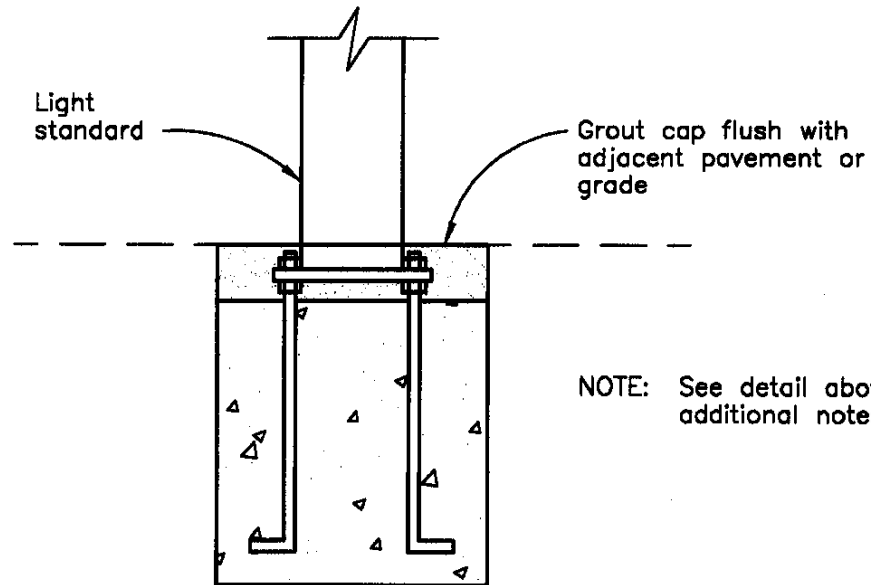

AREA LIGHTING

NOTE: See detail above for additional notes

Dimensions are in millimeters, except as noted

REVISIONS		CITY OF LONG BEACH, CALIFORNIA DEPARTMENT OF PUBLIC WORKS	STANDARD PLAN NO.
NO.	DATE		
1	01/08/98	<b>TYPICAL FOUNDATION DETAILS</b>	METRIC <b>707</b>
2	12/23/02		
3			
4			
APPROVED BY: <i>Mark Smithell</i>		DATE: <i>1/10/03</i>	SHEET
CITY ENGINEER R.E. No. <i>1099</i>		EX. DATE <i>03/31/03</i>	1 OF 1